

# TOOLS FOR BUILDING HEALTHY SOIL

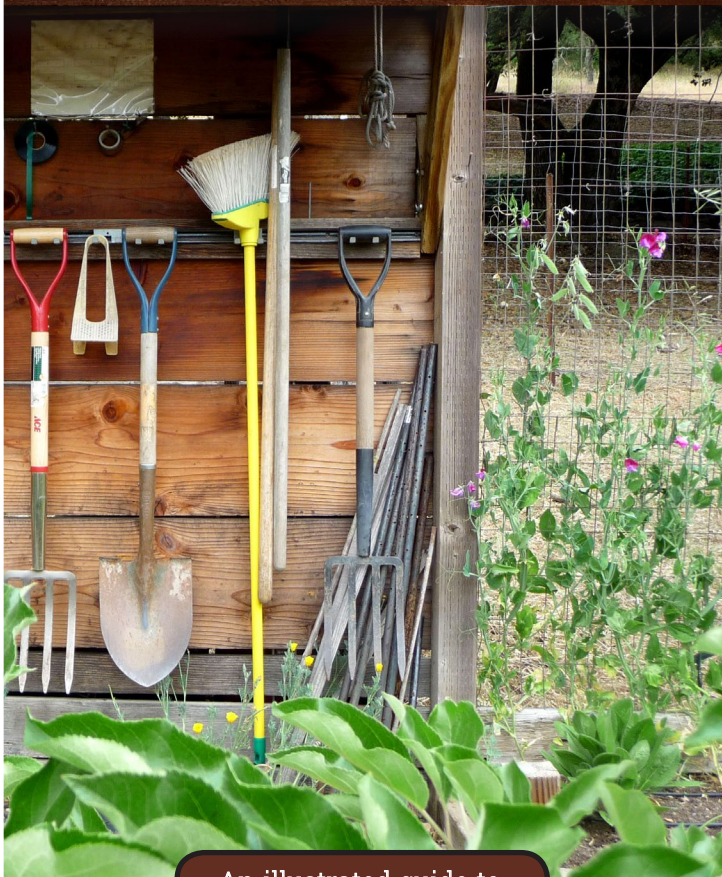

An illustrated guide to

## Making and Using Compost

**STOPWASTE**  
at home • at work • at school

**Healthy soil is the foundation** of a beautiful, bountiful garden. Composting, sheet mulching and cover cropping are a few practices that will help improve your soil. This guide can help you get started at home.

## TABLE OF CONTENTS

Building Healthy Soil . . . . .	3
Backyard Composting . . . . .	5
Worm Composting . . . . .	13
Compost Bins & Designs . . . . .	19
Sheet Mulching . . . . .	25
Cover Cropping . . . . .	28
Carbon Farming . . . . .	30



## BUILDING HEALTHY SOIL



**In a garden,** you are growing two things: plants and the soil. Of the two, many gardeners focus on growing the soil, knowing that healthy plants will follow. Like humans, plants require certain nutritional elements for optimal growth and health. Plants get some of these – carbon, hydrogen, and oxygen – from air or water. The rest come from the soil.

The goal of building your soil is to provide plants with the nutrients that are essential to their health and growth. It is always better to feed the soil with compost, mulch, cover crops, aged herbivore manure, or worm castings, rather than feed the plant alone with quick release fertilizers that can destroy soil life.

In addition to nutrients, gardeners must also consider the soil's basic make-up and texture. Every gardener's ideal is a soil called loam. Dark and wonderfully crumbly, a good quality loam has high organic content, is teeming with life, contains all the nutrients that plants need, holds moisture well, and drains well. The preferred method for improving soil structure over time is mulching or top dressing with organic materials.

Urban soils have often been compacted, eroded, and depleted. Using compost and mulch helps restore the soil's ability to grow healthy plants naturally and to absorb more water, which reduces the need for irrigation and helps control erosion. It also helps plants store more carbon in the soil, and in their stems, plants, and leaves, which is a great way to mitigate climate change.

**This booklet provides information to help you build healthy soil in your garden.**

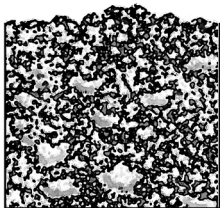
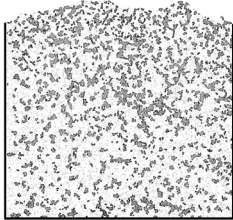
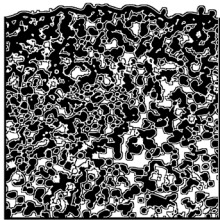
<p>CLAY</p> 	<p>CLAY with COMPOST</p> 
<p>SANDY</p> 	<p>SANDY with COMPOST</p> 

Compost helps loosen clay soil, allowing air and water to penetrate. Compost unites fine particles in sandy soil, allowing greater water-holding capacity.

## BACKYARD COMPOSTING

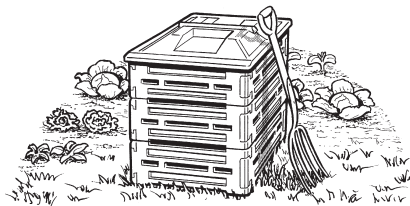

### Composting is nature's way

of recycling. It is a satisfying way to turn your fruit, vegetable and yard trimmings into a dark, crumbly, sweet-smelling soil conditioner.

Composting:

- Fosters living soils that contain high levels of organic matter.
- Saves water by helping the soil hold moisture.
- Increases carbon sequestration by stimulating plant growth and soil microbial activity.
- Improves crop yields.
- Recycles valuable organic resources and keeps them out of landfills.

Not only does composting help the environment, but it can help your garden, yard, and house plants too! Before getting started it is important to consider what you will be composting: food scraps, yard trimmings, or food mixed with yard trimmings. Food scraps include pre-cooked fruit and vegetable trimmings that are no longer edible. Keep in mind, it's always better to use as much food as possible before it goes in the compost bin.

### FOR THE LOVE OF FOOD

Food is too essential to throw away. By making small shifts in how you shop, prepare and store food, you can prevent it from going to waste. For tools and tips about how to get more out of your food, visit [StopFoodWaste.org](http://StopFoodWaste.org).





# DECIDING WHAT TO COMPOST



## SYSTEMS FOR FOOD & YARD TRIMMINGS

### Rodent-Resistant Bins

To be rodent resistant, bins require a lid, floor and no opening greater than 1/4". They are best for composting food scraps and yard trimmings. A good bin can help prevent rodents from nesting.



## SYSTEM FOR YARD TRIMMINGS ONLY

### Open Piles & Simple Bins

Open piles and simple bins should be used for yard trimmings ONLY. Actively maintain these systems by chopping and turning frequently to keep animals out.



## SYSTEM FOR FOOD TRIMMINGS ONLY

### Worm Bins

Worm bins can be placed indoors or outdoors and produce excellent fertilizer. See the Worm Composting section on page 13 for more information.



**Remember:** Whenever you compost food scraps, the County Environmental Health Department requires a rodent-resistant system with a lid, a floor, and no opening greater than 1/4".

# GETTING STARTED

Thanks to beneficial bugs and worms, composting is as easy as "1, 2, 3" no matter which recipe you use!

**1. Chop** materials to help them to break down more quickly.



**2. Mix** "browns" (dry, woody materials) with "greens" (moist, green materials).



**3. Maintain** air & water balance by keeping compost as moist as a wrung-out sponge.

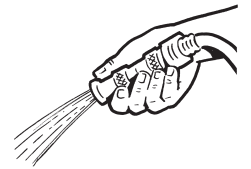

**Browns, Greens, Air and Water** are the "big four" that will keep every compost pile happy.



## DO COMPOST:

- Fallen leaves
- Chopped, woody prunings
- Pine needles
- Sawdust from untreated wood
- Food scraps
- Egg shells
- Lawn clippings
- Weeds without seed heads
- Coffee grounds & filters
- Citrus rinds
- Tea bags
- Herbivore manures: e.g. goats, horses, chickens

## DON'T COMPOST:

- Grains, beans or breads
- Sawdust from plywood/treated wood
- Meat, bones or fish
- Pet feces: e.g. dog, cat, bird
- Diseased plants
- Dairy products or grease
- Large amounts of soiled paper, e.g. pizza boxes
- Bio-plastics, even if they are labeled “compostable”

### *A Word in Favor of Green Bins*

Green bins are a great way to compost organic materials that aren't suitable for your backyard bin. For example, food-soiled paper, dairy products and grains are fine to put in your green bin, but can be problematic in your backyard bin. All cities in Alameda County provide curbside pick-up of compostable materials. Never put glass, metal, or plastic in the green bin. For more information about curbside collection visit [www.StopWaste.org/recycle](http://www.StopWaste.org/recycle).

## RECIPES FOR RODENT-RESISTANT BINS



### “NO-FUSS” COMPOST

For yard trimmings ONLY. Requires a rodent-resistant bin to prevent animal nesting.

#### *Ingredients:*

Yard trimmings only (browns & greens), water as needed



#### *Directions:*

- 1. Feed** chopped or unchopped yard trimmings into bin as you generate them.
- 2. Maintain** compost by keeping it as moist as a wrung-out sponge.
- 3. Harvest** rich, brown, finished compost from the bottom and center of the pile after 12 to 18 months.

### “MIXED” COMPOST

For food scraps & yard trimmings together. This recipe requires a rodent-resistant bin and active maintenance to prevent animal nesting and feeding.

#### *Ingredients:*

Fruit, vegetable and yard trimmings (browns & greens), water as needed.



#### *Directions:*

- 1. Feed** yard trimmings to your pile as you generate them by chopping them first into pieces 6” or smaller. Food scraps need to be buried and mixed into the center of the pile. Never dump

food and run! Be sure to mix in enough browns to balance your greens. Feed as often as you like and always top with browns.

**2. Maintain** compost by turning or mixing it about once a week. Keep it as moist as a wrung-out sponge.

**3. Harvest** rich, brown, finished compost by sifting out coarse, unfinished materials after 3 to 8 months.

## "ACTIVE" COMPOST

For yard trimmings ONLY. In open piles & simple bins, active maintenance prevents animal nesting.

### *Ingredients:*

Yard trimmings only  
(browns & greens), water  
as needed



### *Directions:*

**1. Feed** yard trimmings to the pile after chopping them into pieces 6" or smaller, then mixing them into the pile. Feed as often as you like. Be sure to balance browns with greens.

**2. Maintain** pile by turning or mixing it about once a week. Covering it with a plastic tarp will help keep it moist.

**3. Harvest** a rich, brown, finished compost by sifting out coarse, unfinished materials after 3 to 8 months.

# HARVESTING COMPOST

## *How To Tell When Compost Is Done*

- It looks like soil and smells sweet and earthy
- Pile is 30-50 percent lower in volume
- Original materials are unrecognizable, except some persistent woody pieces

## *Storing Compost*

We recommend "aging" your compost by letting it sit for six months before using. Cover with a tarp or keep in a sheltered space to protect from the rain and sun. Remove the tarp periodically to provide air.

**NOTE:** If unfinished compost is added to your soil, the decomposer organisms compete with plants for nitrogen, resulting in stunted plant growth and yellow leaves.

# TROUBLESHOOTING YOUR BACKYARD BIN

## SYMPTOMS

## PROBLEMS

## SOLUTIONS

Pile not composting

- Too dry
- Too much brown matter

- Add water until slightly damp & turn (mix)
- Add fresh green matter or organic nitrogen

Pile smells rotten/attracts flies

- Too wet/too many food scraps or lawn clippings
- Food scraps exposed
- Non-compostables

- Turn & add browns (dry, woody materials) or dry soil
- Bury & mix food scraps into pile
- Remove meat, dairy, grease, etc. & turn

Rodents in pile

- Food scraps in open bin
- Holes larger than 1/4 inch
- Non-compostables

- Use traps or baits, rodent-proof bin, remove meat, grease, etc. & turn

## WORM COMPOSTING

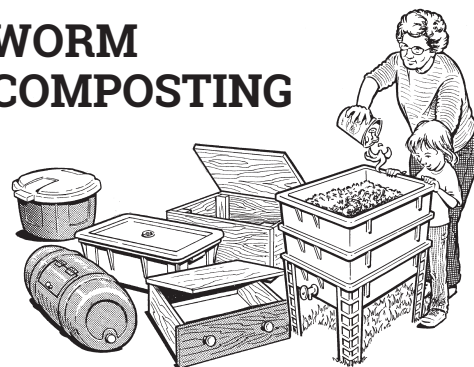

**Worm composting is** a great way to turn your food scraps into a nutrient rich slow release fertilizer. A pound of red worms can eat 65 pounds of food trimmings in less than three months!

### GETTING STARTED

**1. Choose a bin.** Buy a bin, or build one out of wood, plastic, an old dresser drawer, shipping crate, or barrel. Your bin needs to be 10"-16" deep, have a snug-fitting lid, and holes on the sides for ventilation. To keep rodents out, the holes need to be 1/4" inch or smaller. The rule of thumb for bin size is two square feet of surface area per person. An average two-person house would need a bin about 2'x2' = 4 square feet, or two bins that are 1'x2' = 2 square feet each.

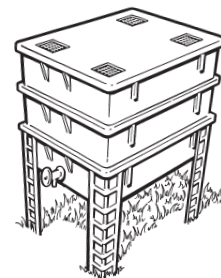

**2. Pick a place.** Locate your bin where it will not freeze or overheat — in a pantry, kitchen corner, laundry room, garage, basement, patio, deck, or in your garden.

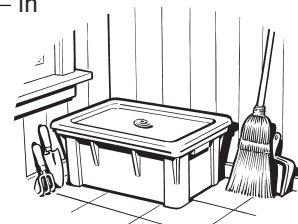

**3. Make a worm bed.** Worms like to live under lots of moist paper or leaves. This helps keep them cool and moist, gives them fiber to eat, and prevents fruit flies from getting to the food.

To make your worm bed, tear black & white newspapers into one-inch strips, fluff them up, then moisten them so they are completely wet but not dripping. Fill your bins 3/4 full with this moist “bedding.” Shredded, corrugated cardboard, leaves, compost, sawdust and straw can also be added in as bedding. Sprinkle bedding with a few handfuls of soil. Do not use glossy paper or magazines.

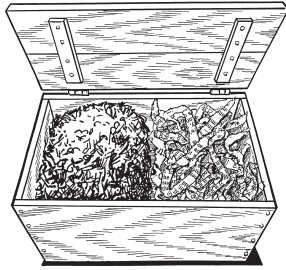

**4. Adopt some worms.** Compost worms are often called “red worms” or “red wigglers.” They are different from earthworms and nightcrawlers who live underground. You can get red worms from a friend’s worm bin or buy them from a worm farm (visit [www.StopWaste.org/worms](http://www.StopWaste.org/worms) for a list of worm sources). Start with one half to one pound of worms, or two nice big handfuls.



**5. Feed worms their first meal.** Start your worms off with about a quart of fruit and vegetable scraps. Then leave them alone for a couple of weeks while they get used to their new home.

#### ***DO FEED YOUR WORMS:***

- Fruit and vegetable scraps
- Shredded paper
- Egg shells
- Coffee grounds & filters
- Tea bags

#### ***DON'T FEED YOUR WORMS:***

- Grains, beans or breads
- Meat, bones or fish
- Oily or salty food
- Dairy products or grease
- Citrus

#### **MAINTAINING YOUR WORM BIN**

Feed your worms about a quart (one pound) of food scraps per square foot of surface area in your bin per week. To avoid fruit flies and odors, always bury food under the bedding. Don't dump and run!

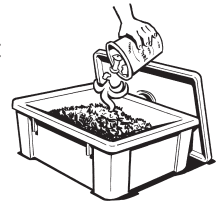

Add fresh bedding every time you feed the worms. Always keep a 4” to 6” layer of fresh bedding over the worms and food in your bin.

Keep bedding as moist as a wrung-out sponge. In a plastic bin, add dry bedding to absorb excess moisture. Wooden bins may require adding water occasionally.

#### **HARVESTING WORM COMPOST**

Harvest worm compost at least once each year to keep your worms healthy. You can start harvesting 2-3 months after you set up your bin. Simply reach in and scoop out the brown crumbly compost, worms and all.

You can also move the contents of your bin to one side, place fresh bedding and a handful of soil in the empty space and bury food there for a month or two. Harvest the other side after the worms have migrated to the new food and bedding. It's best to use castings soon after you harvest or store in a plastic bag to keep the castings moist.



# TROUBLESHOOTING YOUR WORM BIN

SYMPTOMS	PROBLEMS	SOLUTIONS
Worms are dying	<ul style="list-style-type: none"> <li>• Food and bedding all eaten</li> <li>• Too dry</li> <li>• Extreme temperatures</li> </ul>	<ul style="list-style-type: none"> <li>• Harvest compost, add fresh bedding &amp; food</li> <li>• Add water until thoroughly moistened</li> <li>• Move bin so temperature is between 40-80° F</li> </ul>
Bin attracts flies and/or smells bad	<ul style="list-style-type: none"> <li>• Food exposed/overfeeding</li> <li>• Non-compostables present</li> </ul>	<ul style="list-style-type: none"> <li>• Add 4"-6" layer of bedding &amp; stop feeding for 2-3 weeks</li> <li>• Remove meat, pet feces, etc.</li> </ul>
Sowbugs, beetles in bin	<ul style="list-style-type: none"> <li>• These are good for your worm compost</li> </ul>	

## USING COMPOST

Compost boosts fertility, enhances soil structure, and improves nutrient and water retention. It also encourages microbial activity, which not only leads to vigorous and healthy plants but also helps mitigate climate change by increasing the amount of carbon your garden can store.

Here are some of the best ways to use compost:

### Soil Amendment

For establishing new edible garden beds, work a 4" to 8" layer of compost into the soil. After this initial heavy application, switch to topdressing as needed to keep your soil healthy.

### Topdressing

Spread a 1/2" to 2" layer of compost on top of the soil at least once a year.

For turfgrass, spread a 1/2" layer of sifted, weed-seed-free compost as a topdressing. For worm compost, sprinkle a 1/4" to 1" layer at the base of plants. Topdressing can be done any time of year to improve soil fertility and reduce watering needs.



### Potting Mixes

Sifted compost can be used to make a rich, loose potting soil for containers, houseplants or starting seedlings from scratch.

Compost or worm compost potting mix increases moisture storage and provides a variety of nutrients not typically supplied in commercial fertilizers or soil-free potting mixes.



**NOTE:** Do not use pure compost as a planting medium; it should always be mixed with other materials, and blend no more than 20% worm compost into potting mix or garden soil.

### Recipe for starting seedlings:

- Sift compost through a 1/2 inch or smaller mesh.
- Mix 1 part sifted compost, 1 part fine sand (available at nurseries) and 2 parts garden soil.
- Use compost tea (see below) when true leaves emerge.

### Recipes for containers and house plants:

- Sift compost through 1/2 inch mesh screen or remove large particles by hand.
- Mix equal parts loamy soil, sand and compost. Add 1/2 cup of bloodmeal or cottonseed meal.
- Add 1 cup of rock phosphate and 1/2 cup of kelp meal for additional nutrients.



### Diluted Worm Compost

Add water to worm castings at a 10:1 ratio and pour onto the root zone of plants and trees

### Compost Tea

Compost tea is rich with microbes and is excellent for plant growth promotion and disease prevention. It can also be used as a soil drench, as a foliar spray or to soak seeds to increase their germination rate.

Fill a five-gallon bucket 1/3 full with finished compost (either worm or backyard).

Fill the remainder of the bucket with non-chlorinated water (ideally). Let it brew for a few days, stirring every day to add oxygen or use an aquarium bubbler for 24 hours.

Filter off the liquid tea and dilute the mixture to a light amber color if it is very dark.

**NOTE:** the liquid that comes from your worm bin is not compost tea, but a leachate that can be harmful to your plants.



## COMPOST BINS & DESIGNS

It is important to know what you want to compost when choosing your bin system.

Please see the tips below for different compost systems.



	WORM BIN	BACKYARD BIN
<b>MATERIALS TO COMPOST</b>	<ul style="list-style-type: none"> <li>• Food trimmings only</li> </ul>	<ul style="list-style-type: none"> <li>• Food trimmings and yard debris</li> </ul>
<b>PROS</b>	<ul style="list-style-type: none"> <li>• Requires little space</li> <li>• Can use indoors or outdoors</li> </ul>	<ul style="list-style-type: none"> <li>• Can compost both yard debris and food trimmings</li> </ul>
<b>CONS</b>	<ul style="list-style-type: none"> <li>• No yard waste</li> <li>• Do not put in direct sun</li> <li>• Can require troubleshooting</li> </ul>	<ul style="list-style-type: none"> <li>• Most designed for "cold piles"</li> <li>• Must have volume of at least 3'x3'x3' (1 cubic yard) in order to make a hot pile.</li> </ul>
<b>NOTES</b>	<ul style="list-style-type: none"> <li>• Make a worm bin by drilling holes in a 10-16" deep plastic storage bin.</li> <li>• A tiered bin in which worms migrate from one level to the next makes harvesting easier.</li> <li>• For purchased bins, check for sturdiness of legs and snugness of lids.</li> </ul>	<ul style="list-style-type: none"> <li>• Add a 1/4" or smaller wire mesh base to make a bin rodent resistant.</li> <li>• Check bin for sturdiness.</li> <li>• Harvesting a bin from a "door" can be complicated. Look for a bin that is easy to disassemble and reassemble.</li> </ul>

# BUILD YOUR OWN BIN

You can make a compost bin at home. Choose a system that fits your needs and follow the building directions.

**NOTE:** If you don't want to make your own, commercial bins can be purchased at local nurseries, hardware stores or online. For more information visit [www.StopWaste.org/compost](http://www.StopWaste.org/compost).

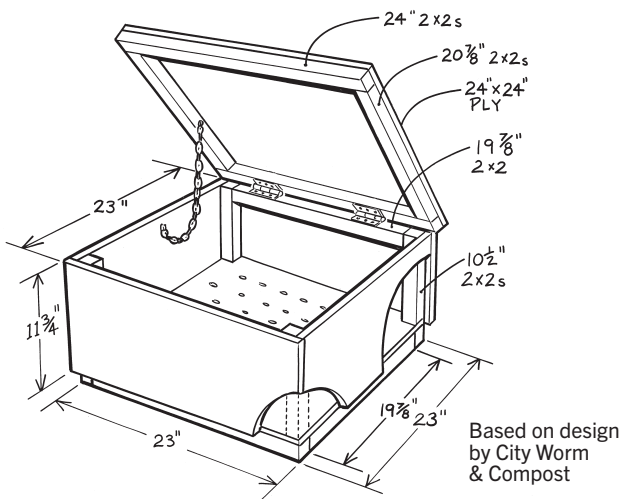

## WOODEN WORM BIN

- For family of two
- Basic carpentry skills needed for construction
- Doubles as a seat!
- Breathes well — will need occasional watering

### Materials

- (1) 4'x4' piece exterior grade plywood
- (3) 6' pieces 2"x2" wood
- (1) 4' piece 2"x4" wood
- 1 pound 4-penny galvanized nails
- 16" light chain with (2) 1/2" wood screws
- (2) 2" hinges, with 3/4" wood screws
- Waterproof wood glue

### Tools

Power saw (use eye protection) or hand saw, hammer, measuring tape, pencil, square, drill with 1/4" and 3/32" bits, sandpaper.

### Assembly

(Glue all wood pieces before nailing)

**Base:** Nail the two 23" 2x4s and two 19-7/8" 2x2s to bottom of 23x23" plywood as drawn. Drill several 1/4" holes for drainage.

**Side, Front and Back Walls:** Nail the four 2x2 uprights to the two side walls along the 11-3/4" edge, with one end of each 2x2 flush with the top edge of the walls. Nail a 19-7/8" 2x2 hinge support to the top edge of the back wall piece, leaving 1-1/2" on each side for 2x2 uprights. Assemble box by nailing the 1-1/4" overhang of the side walls to the 2x2s on the base as drawn. Then nail the front and back walls to the 2x2 uprights and to the 2x4s on the base as drawn. Be sure the hinge support is at the top of the bin.

**Lid:** Nail lid together as drawn. Attach to box with hinges, making sure to pre-drill screw holes into the 2x2s, and position hinges as in detail. Attach chain with 1/2" wood screws so lid can rest in an opened position.

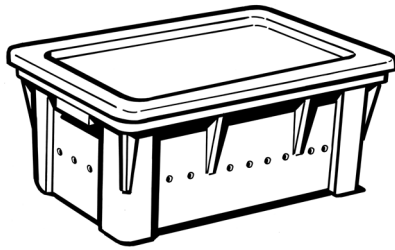

## PLASTIC WORM BIN

- Composting system: fruit and vegetable trimmings alone
- Very easy to build; tidy for indoor use
- Plastic bins keep compost moist — will require regular additions of dry bedding
- \$6 - \$20 for new materials

### Materials

- (1) Plastic storage container with a tight fitting lid  
- 12" to 18" tall, 12"x24" base

### Tools

Power drill (1/4" bit) or utility knife

### Assembly

For indoor use, drill several holes for ventilation about halfway up the sides of the bin. For outdoor use, holes can be drilled in the bottom for ventilation and drainage. Keep holes small to reduce fly infestation.

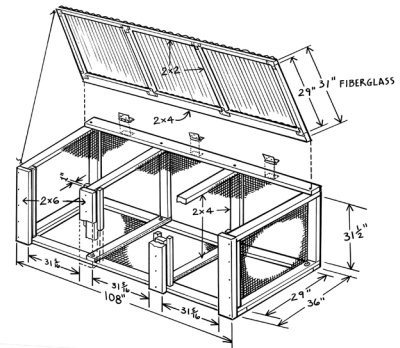

## 3-BIN WOODEN BIN

- Excellent for hot-composting—has removable front slats for easy turning, and separate bins for turning and aging compost, and/or storing compostables
- Can handle large amounts of compostables
- Requires minimum 3'x9' of yard space
- Carpentry skills needed for construction

### Materials

- 2x4" wood\*: (8) 31 1/2", (8) 36", (4) 9', and (4) 29" pieces
- 2x6" wood: (4) 36" pieces
- 2x2" wood: (6) 34 1/2", (1) 9', and (4) 29" pieces
- 1x6" wood: (19) 31" pieces
- 1/4" mesh hardware cloth: 30'x3'
- Carriage bolts (3-1/2"x3/8"): 12, with washers and nuts
- 12 penny galvanized nails: 2 pounds
- 8 penny galvanized nails: 1 pound
- Poultry wire staples: 1 pound
- Corrugated fiberglass (4 oz.): (2) 8'x26" pieces
- Gasketed roofing nails: (40)
- Wiggle molding: 18 feet
- 3" hinges (zinc plated, galvanized or brass): (3)
- 4" flat corner braces: (4) with 1" wood screws
- 4" flat "T" braces: (4), with 1" wood screws
- (4) hook eyes, and 8' of strong twine or chain



\* You can make a two bin composter for a smaller yard by carefully adapting the materials list, drawings, and assembly instructions.

## Tools

Power saw (use eye protection) or hand saw, drill with 3/8" and 1/16" bits, screwdriver, hammer, tin snips, tape measure, pencil, socket or wrench, carpenter's square.

## Assembly

**Main structure:** Butt nail two 31 1/2" and two 36" 2x4s together with 12 penny nails to form each of four screen dividers. Cut four 36x33 1/2" wire mesh pieces, and staple (every 4") to frames after checking frames for squareness. Bolt dividers to three 9' 2x4s as shown (inside measurement between dividers should be 31 5/16"). Tack in 29" 2x4s as shown. Staple one 9'x3' piece of wire mesh (every 4") to back of structure, and one 9'x3' piece to the bottom.

**Slats and slat tracks:** Nail 2x6s to front of dividers. Nail 34 1/2" 2x2" onto frames as shown. Leave at least 1" for the slats to slide in. The last slat of each bin section needs to be cut lengthwise to fit.

**Lid:** Assemble lid frame as shown, with flat corner and "T" braces on the bottom side. Pre-drill nail holes every couple of feet into wigggle molding humps, and attach molding to 9' 2x2 and 9' 2x4 with 8 penny nails. Note position of wigggle molding on 2x4 in drawing. Cut fiberglass into five 32" pieces with tin snips. Pre drill fiberglass and wigggle molding on top of every third hump, and nail together with gasketed nails. Be sure to overlay fiberglass pieces at least one channel wide, and before attaching the last piece, trim off excess fiberglass. Attach lid to frame with hinges. Attach heavy duty twine or chain to lid and main frame with hook eyes as shown (to prevent lid from falling all the way back).

# SHEET MULCHING



**Did you know** that you don't need chemicals to kill your water-thirsty lawn? Sheet mulching is an easy process of layering cardboard, compost and mulch right on top of the grass. Plus, you can plant your new garden straight into the mulch. Sheet mulching is the California Department of Water Resources preferred lawn replacement method.

## *The benefits of sheet mulching:*

- Saves time, money, and water.
- Builds healthy soil.
- Creates attractive drought-tolerant gardens.
- Increases carbon sequestration by stimulating soil microbial activity and plant growth.

Get more details and find resources that will make your lawn conversion project easier, visit [www.LawntoGarden.org](http://www.LawntoGarden.org).

## GETTING STARTED

### *STEP 1. Prep the Site*



Knock down or mow existing vegetation so it lies flat. Remove only woody or bulky plant materials. Soak area with water to start the natural process of decomposition.

Remove woody, bulky and invasive plants such as blackberries, oxalis,

horsetail, kikuyu and Bermuda grass.

Edge the lawn to avoid run-off and keep mulch from spilling onto paving; be sure to shovel around the edges so that the soil is at least 3 inches below the top of the paving. The excess soil can be mounded away from the edges and sheet mulched in place. If you're sheet mulching a lawn, just flip the edges so the roots and soil are face up. Plants that prefer well-drained soils work well on mounds, e.g., natives, and they can create visual interest in the garden by adding height and depth.

### **Step 2: Plant Larger Plants**

Plant 5 gallon or larger plants. Smaller plants will be planted after the weed barrier, compost and mulch are added.



### **Step 3: Add Cardboard**

Add a weed barrier that is permeable to water and air. 'Scavenged' cardboard boxes are ideal, and can be found at appliance stores or bike shops.

You can also buy recycled cardboard rolls. Do not use plastic or other types of weed cloth that do not degrade. Overlap the pieces by 6-8 inches so the sun won't get through. Any lawn showing at the end of the project will come right back. Two layers of cardboard works



well. Wet down the cardboard as you go to keep it in place and to shape it around obstacles.

### **Step 4: Layer Compost & Mulch**

Spread 1-1/2" of compost directly over the cardboard and then cover it with 3 inches of mulch to optimize water conservation and weed control.

The top layer of mulch mimics the newly fallen organic matter of a forest. Good materials include tree trimmings or recycled mulch.

Use the Materials Calculator at [www.LawntoGarden.org](http://www.LawntoGarden.org) to estimate how much material you will need, and locate vendors who sell bulk compost, mulch, and cardboard rolls.

### **Step 5: Plant Smaller Plants**

Gently move the mulch and compost to expose the cardboard. Punch or cut holes in the cardboard and plant into the soil. Add compost around the rootball, if desired. Place smaller plants, e.g., 4 inch pots, directly on top of the cardboard and gently put the compost and mulch layers back into place around the plant.



### **PREVENT POTENTIAL PROBLEMS**

- As with any mulch, do not pile materials up against the trunks or stems of plants to prevent disease. Keep mulch at least 1 foot away from the foundation of your house.
- Small seedlings will need protection from snails and slugs that will seek cover under the mulch, especially during the dry season.
- Use physical barriers to protect young trees from rodents.
- Keep an eye out for re-sprouting invasive plants and remove immediately.
- Sheet mulching can be done any time of year, although it's preferable to do it in the fall to take advantage of the winter rains.

For more details and resources, such as a materials calculator, vendor marketplace, how-to videos and information about irrigation rebates, visit [www.LawntoGarden.org](http://www.LawntoGarden.org).

# COVER CROPPING



## Cover cropping involves

growing a green manure that will be worked in to build up the soil. Most gardeners use a blend of legumes, such as fava and bell beans, and grasses, such as oats and rye. Legumes have the ability to draw nitrogen from the air and incorporate it into their bodies and root systems. When they are cut down and worked into the soil the nitrogen is released and becomes available to other plants. Grasses provide a structure for the legumes to grow up, and add bulky organic matter when they are cut down. Most nurseries carry cover crop seed blends.

Cover cropping is an important part of intensive edible gardening and can be included in crop rotations. It is also a good way to pull carbon out of the atmosphere and store it in the soil—feeding your garden with CO<sub>2</sub> and helping mitigate climate change.

### Cover cropping:

- Adds nitrogen and organic matter
- Protects soil from erosion
- Breaks up compaction
- Increases carbon sequestration
- Attracts bees and other pollinators

## GETTING STARTED

**1. Start by clearing** out old crops and preparing a bed for planting.

**2. Broadcast cover crop seed** onto your garden beds in time for the fall rains in mid-to-late October. Sow about one to two pounds per thousand square feet. Use a rake or garden fork to work the seed in and cover it with soil. When the rains start the seeds will germinate and grow through the winter.

**3. In the spring**, when about a quarter of the legume's flower buds open, use garden shears to cut the cover crop down and then work it into the soil with a hoe or garden fork. It is best to cut the legumes down before they start using their stored nitrogen to make seeds. Just leave the roots in place, they add organic matter and improve drainage. It will take a couple of weeks to a month for the crop residue to break down.

# CARBON FARMING

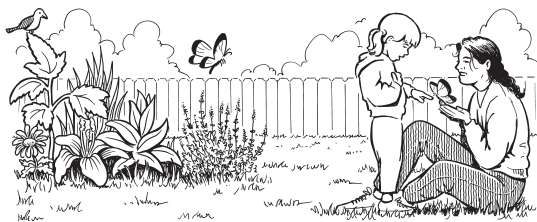

Carbon farming in your garden increases the amount of carbon dioxide plants pull from the atmosphere to store in their bodies and in the soil. It's a great way to mitigate climate change while creating a more resilient landscape.

## CARBON FARMING PRACTICES:

- **Use compost.** Feed your soil with compost to make your garden more resilient to drought and disease. Not only will the compost directly add carbon to the soil, it will also help plants take in more CO<sub>2</sub> from the air and store it in their stems, plants and leaves
- **Minimize disturbance.** Rototilling destroys the microorganisms and fungi that bind up carbon in the soil. Instead of tilling, try sheet mulching when preparing your garden beds.
- **Maximize continuous living roots.** Woody perennial plants store large amounts of carbon in their roots, and create the perfect environment for beneficial microorganisms and fungi. If you are growing annual vegetables, plant cover crops after you harvest instead of letting your land lie fallow, or planting cover crops with your vegetables.
- **Maximize soil cover.** Keep unplanted areas covered with mulch. A thick layer of wood chips, straw, tree leaves, or compost helps soil retain moisture, encourages microbial activity, and prevents erosion.

- **Maximize biodiversity.** The more diverse your plant community, the more diverse the soil food web will be, which helps prevent pests and pathogens from harming your plants, and creates excellent habitat for the beneficial microbes that enable plants to store carbon.
- **Avoid synthetic fertilizers, pesticides, and herbicides.** Synthetic inputs negatively impact the macro and microorganisms that keep carbon locked up in your soil. When synthetic nitrogen fertilizers are exposed to water the reaction produces nitrous oxide, a very harmful greenhouse gas.







1537 Webster Street  
Oakland, CA 94612